

# THE ORGONE POWERED RESONANT MOSQUITO REPELLER

*PLEASE READ THIS INFORMATION FIRST - DO NOT TRY AND CONSTRUCT THE REPELLER UNTIL YOU FULLY UNDERSTAND HOW IT WORKS AND THE ABSOLUTE RESPONSIBILITY YOU HAVE TO CONSTRUCT IT CORRECTLY AND APPLY THE RIGHT AND HONOURABLE INTENT.*

Email: [brian.may@wn.com.au](mailto:brian.may@wn.com.au)

## Firstly, a Brief History of how it all started.

Everything is energy, from the humblest atom through to the most complex structure.

Since childhood, I have been driven to discover everything possible about the subtle energies which pervade our lives and as such, the whole unseen universe that surrounds us.

## Everything is Resonance (Energy).

Every living species has a resonance which sets it apart from all others. And everything is affected by energetic vibrations or resonance. As an example, we know the effects that Electromagnetic Radiation can have and how it can throw our systems out of balance, often to the point that sufficient disharmony is created that we can succumb to all kinds of illness and disease. However, with a strong belief in ones ability to direct intent towards using this infinite energy to protect and heal us from the effects of induced disharmony, we can in many ways take control of our own healing.

When I gained some understanding of the infinite energy that surrounds us, is when it all started to come together for me. I started to feel comfortable accessing the state of consciousness that allowed me to vaguely understand this infinite source of energy and to realise that it is available to all of us whose intentions are genuine and free from greed and negative intent. Sadly, the world is full of exploitation, usually for the shallow, short term satisfaction of personal gain or collective greed and power.

The natural Universal (Cosmic) laws are accepted by the practitioners of dowsing, radionics, biodynamics and other arts and crafts that work on the energetic planes which are beyond the measure of mainstream science.

Are you getting impatient to build the Repeller yet? - Please be patient as it is important, no, not important; *it is essential*, you have the right intent, understanding and attitude as you go through the process of constructing the Repeller.

*Take my word for it, these Repellers cannot be made in a dollar a month sweat shop by a bonded nine year old child, or under any other process that is based on greed, exploitation or excessive profit; they just wont work because that type of environment does not allow for the harmony of good intent to be part of the process.*

Millions of dollars are spent each year in attempts to protect people from the effects of Mosquito borne diseases and many more millions of dollars profit is made providing synthesised drugs which generally have a limited period of effectiveness and so the cycle continues whilst millions suffer and die.

The energies used by the Repeller are part of the fabric of the unseen Universe. These energies do not belong to any individual, nation, religion or organisation and are freely available to all who are willing to work beyond the constraints of conventional science and the rational left side of the brain.

With this simple Repeller device which requires no artificial power; we can protect ourselves and our families from annoying mosquitos and the potential of infection from the diseases they can carry. In my location, the Repeller has an effective range of around six metres and faithfully works 24/7 without any maintenance apart from occasionally adding a little distilled water to make up for natural evaporation. I am currently working on a large area multi purpose Repeller/broadcaster, but need to test it for at least a year before I release details on it.

### **How does it work?**

There are possibly other explanations on how it works, but the following tends to fit more with my reality. However, those who rely mainly on the left side of the brain may have great difficulty in explaining its operation, or even just accepting the fact that it works at all. I have a friend, although he is a very creative Engineer is left brain dominated, and knows the Repeller works extremely well but his existing reality will not allow him to contemplate its mode of function.

The atmosphere and the earth have a different polarity and ranges of frequencies. These are kept in reasonable balance by the normal atmospheric activity including lightning which is discharging and rebalancing more than eleven

hundred times a minute somewhere on earth. All living creatures are affected by the potential difference of these energies. If we create a localised imbalance which is confined to the resonant frequencies of a specific organism or creature; we generate a climate of disturbance in which it cannot function.

The Repeller draws energy from these two sources; the atmosphere and the earth, and amends this energy to create a specific imbalance to the Mosquitos' resonance.

The upper two coils channel the specific energies from the atmosphere and the lower coils, from the earth. These differing frequencies are brought together and the resulting amended resonance is radiated from the matching parallel wires between the two sets of coils.

Because it is more convenient to locate the Repeller above ground, the 300 mm square of Alfoil acts as an artificial ground plane or collector, whilst the jar containing the quartz sand and saline solution acts as a buffer or capacitor which helps maintain an even discharge or transmission. Final tuning of the unit is carried out by adjusting the position of the terminal block whose function is to allow tuning to suit the specific location.

Each location is slightly different as the natural energies may vary for many reasons such as electromagnetic interference, local mineralisation in the soil or other factors which can be associated with the species of Mosquito that needs repelling. The area around the Repeller must be kept clear of loose metal objects and crystals.

***Correct tuning for the locality is absolutely essential.***

Ok, let's start building the Repeller. Study the drawing, make yourself completely familiar with all the details and make sure you have all materials on hand. **DON'T** rush the job, it is absolutely important that you take your time and have pride in what you're building; remember, this is unique! Whilst you are building it, **you are putting your energies and intent into it; be proud of it, have confidence in your ability and "KNOW" that it will work!**

**Firstly check out your Bamboo, Wooden or Fibreglass shaft;**

If you intend to use bamboo, find one which is as straight and uniform in diameter as possible; although a slight tapering will not have any great affect on the outcome. If you cannot find Bamboo, a wooden dowel of the right dimension will work ok and a solid fibreglass rod certainly will, but I would not use any other synthetic material such as PVC, often these contain conductive contaminants which may cause problems. A shaft length of 500 mm is a good length to start with and can be trimmed as the project nears completion.

Drill the 1 mm holes as shown on the drawing; try and keep them in a line as much as possible. The distance between the holes is critical so make sure you get them right. Take a permanent marker pen and carefully measure and mark the exact locations of the two 3 mm straight sections as marked on the plan. The first two marks will be at 100 and 103 mm from the first hole. The next marks will be at 110 and 113 mm below hole No 3.

Now take a few cable ties of about 3 mm wide. Commence them as ties but leave a loop of at least 30 mm. This preparation will make it much easier to fasten the wire to the shaft when holding things together becomes awkward.

**Winding the coils** - this can be difficult so if possible, secure the shaft in a vice or similar clamp so that both hands are free to work on the windings. Starting at the top, push sufficient wire through the top hole so that it can be bent to point upwards; leave about 60 mm of wire above the top of the shaft. Use one of the prepared cable ties to secure the wire to the shaft just above the first hole. Pull the tie very tight and trim off the excess tie.

**This is important!** - commence winding the wire in an **ANTICLOCKWISE** direction (looking down from the top of the shaft), wind 5 turns and evenly space the windings so that the 5<sup>th</sup> winding finishes right on the first mark (@100 mm). Now, holding the wire in place, create a sharp bend in the wire so that it runs directly down the shaft for 3 mm. Take another cable tie and place it over this straight section and tighten. At the second mark bend the wire again so that you can continue to wind in an anticlockwise direction for another 7 turns.

Evenly space the coils so that the 7<sup>th</sup> finishes directly over the 2<sup>nd</sup> hole. Allow about 70 mm of wire to protrude past the 7<sup>th</sup> coil then cut off the rest. Pull the excess 70mm through the hole and make sure it is tight against the shaft.

Commence the next coil by pushing about 70 mm of wire through the next hole and in the same direction as the other piece. Commence winding the next coil, making 8 full turns **CLOCKWISE** to match with the next mark. Put a sharp bend in the wire so that it is once again parallel with the shaft. Use another cable tie to hold the wire in place.

At the next mark bend the wire so that you can again start winding the last coil of 3 turns also in a clockwise direction making sure you finish the last winding over the last hole. Cut the wire about 220 mm past where it reaches the hole and pass this through the hole and using another cable tie hold it in place near the bottom of the shaft.

**So, that's it!** - All that we need to do now is trim everything to the right length as shown on the drawing.

**Preparing the terminal block** - there are two ways of doing this; you can use two terminal blocks but you will have to use a piece of uninsulated wire to bridge the two blocks.

The second method is easier to use but needs a little more preparation. Take one terminal block strip the plastic off it and remove the two screws. Drill two 1 mm holes in the terminal block at right angles to, but in line with the screw holes. Replace the screws. This will allow you to insert the two tuning wires through the drilled holes when doing the final tuning.

Fill the glass jar at least 80% with the quartz sand.

Take a litre of water and add 2 grams of sea salt, mix well.

Push the repeller firmly into the sand, but keep the last coil clear of the sand.

Slowly add the prepared water and allow the air to escape from the sand. Keep adding water until the level stabilises about 10 mm above the surface of the sand. You may have to support the shaft until the sand consolidates.

Now for the final tuning - place the completed Repeller exactly where you plan to leave it operating. Lay out the Alfoil sheet and place the Repeller in the centre.

Take the terminal block and slide it over the two tuning wires. If you can dowse, keep dowsing for a positive reaction as you slide the terminal block along the wires. Once you have received a positive reaction, tighten the two screws to prevent the terminal block moving.

If you cannot dowse, set the terminal block at around 15 mm from the shaft. You may have to experiment to ensure you get the correct setting.

**That's it!** - **If you have done everything correctly, the Repeller is already working and will continue to do so for as long as you wish. Keep an eye on the water level and make sure it covers the sand completely. Just top up with distilled water occasionally to keep the sand covered. And Most Important! - Thank the Cosmic for making the energies and knowledge available.**

More info: [brian.may@wn.com.au](mailto:brian.may@wn.com.au)

## Orgone Powered Resonant Mosquito Repeller

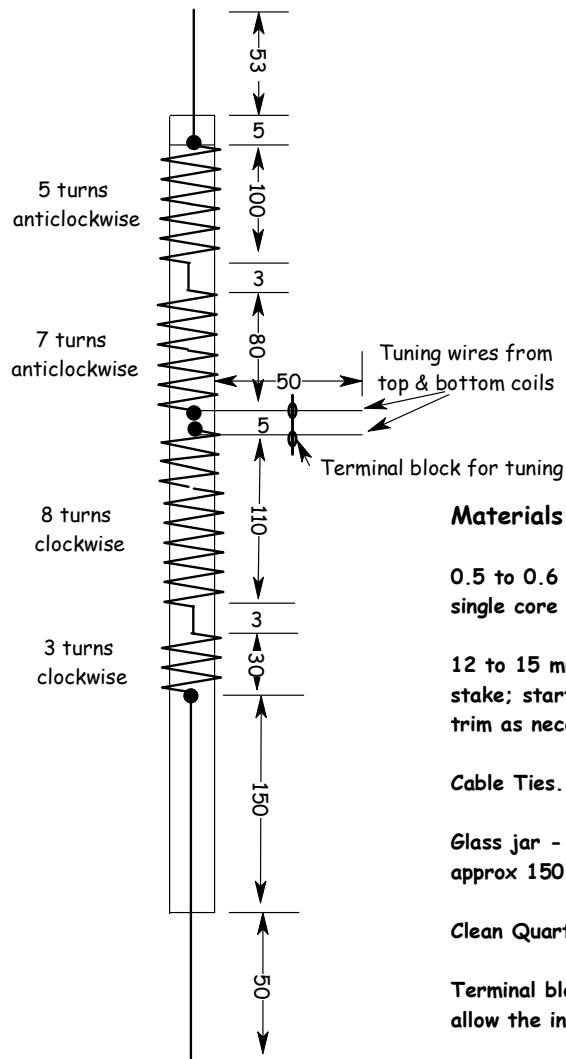

● = 1 mm drill holes

**Note: All measurements in Millimetres**

### **Materials:**

0.5 to 0.6 mm Enamelled single core Copper wire.

12 to 15 mm Dia Bamboo or Fibreglass stake; start with a 500 mm length and trim as necessary.

Cable Ties.

Glass jar - 50 to 100 mm wide by approx 150 mm deep.

Clean Quartz Sand. (fine grain)

Terminal block drilled through sides to allow the insertion of tuning wires.

1 Litre of distilled water.

2 grams of Sea Salt.

300 x 300mm square of Aluminium foil.

A few Notes on its Operation.

Providing you have done everything correctly the Repeller will be working.

Take note and you may observe:

- Male mosquitos may not be affected - they are vegetarian anyway.
- Female Mosquitos will either keep clear or will act in a stupefied manner they may cling to doors, windows or walls but will have no desire to bite whilst within range of the repeller.
- If you have more than one species of mosquito in your location, you may have to tune the Repeller to get rid of the disease carrying or most persistent type - this will rarely need to be done.
- Try and keep the Repeller clear of any electromagnetic source and if possible douse for the best location. Also ensure that all loose metal objects and crystals are kept clear of the Repeller - the Alfoil should be kept clean and flat.
- You may notice that for the first 10 or so hours of operation some strange phenomena may occur - often smoke alarms may be triggered until the energies balance. Other things have also been observed but these will pass after a few hours and the environment has balanced to accept the new source of energy.

**DO NOT TRY AND MAKE MONEY OUT OF THIS REPELLER!**

**DO NOT TRY AND MAKE MONEY OUT OF THIS REPELLER!**

**DO NOT TRY AND MAKE MONEY OUT OF THIS REPELLER!**

**The Universe has presented this information to me  
for the benefit of all mankind and not for the  
greedy exploitation by unenlightened individuals.**

Other Repellers and broadcasters have and are being developed for many different applications.

Further information can be obtained from: [brian.may@wn.com.au](mailto:brian.may@wn.com.au)